

# DIRECT SERIES

*Pre-engineered, expedited  
delivery equipment options*

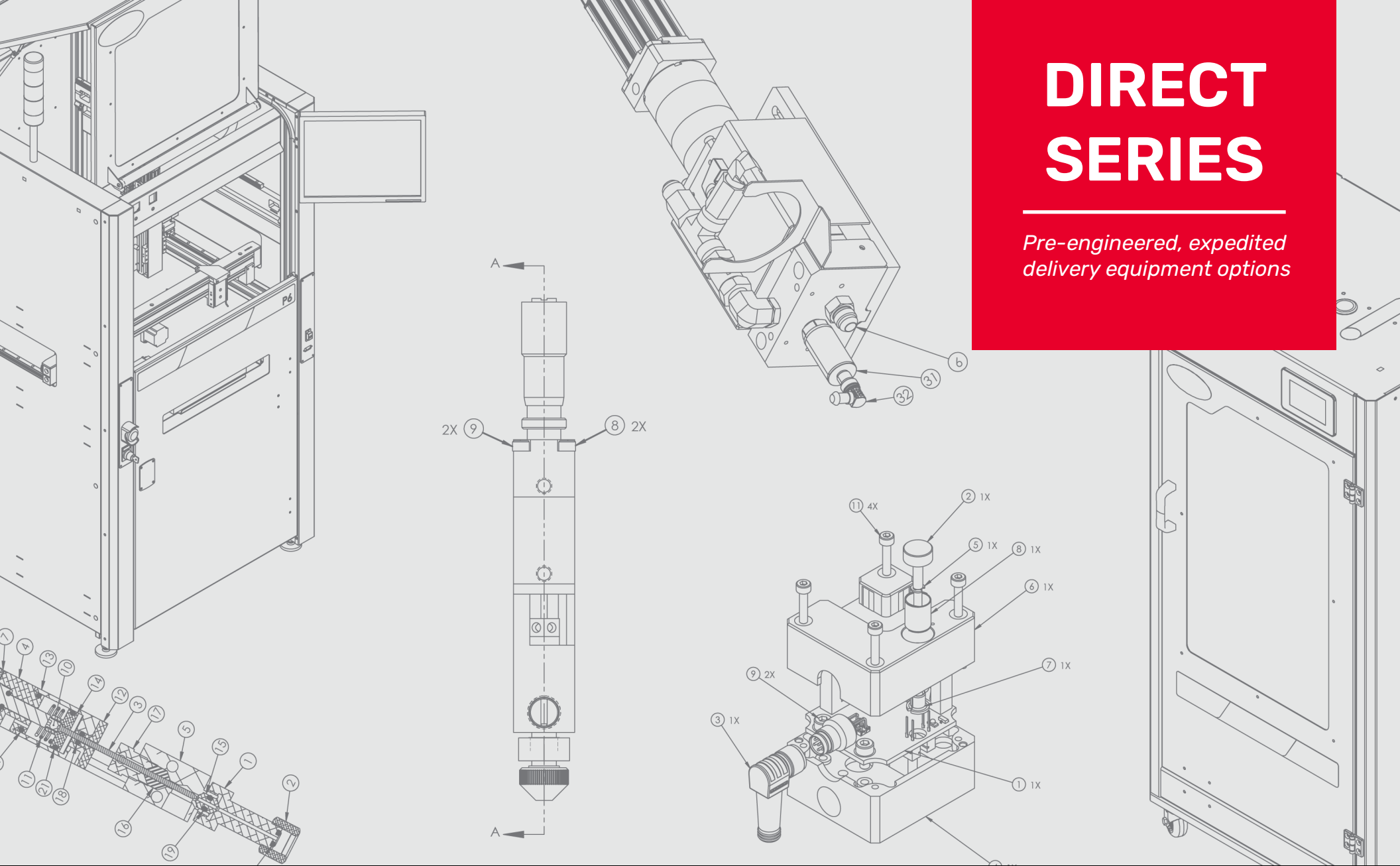

**PVA**

info@pva.net • pva.net • +1-518-371-2684



**PVA's Direct Series** is a lean manufacturing process featuring pre-engineered solutions that allow customers the flexibility to acquire new equipment customized for their application with shorter lead times.

This brochure contains a small sampling of the thousands of combinations available to you from our **Direct Series** configurator. With the help of our sales team, a solution can be designed in minutes and will go directly into production and ship to meet the demands of your manufacturing schedule.

Equipment and options available in the **Direct Series** are always expanding. Current equipment choices include:

- Delta 8 Automated Dispensing / Coating System
- Delta 6 Automated Dispensing / Coating System
- Endurance Metering System
- Sigma Benchtop Robot
- DeltaTherm Infrared Curing Oven
- Spectra UV Curing Oven
- BI2000 Board Inverter
- Queue Inspection Conveyor

For more information on how the **Direct Series** can help you meet your manufacturing needs, contact your local PVA sales representative at **+1-518-371-2684** or **info@pva.net**.

REV B - 2/2024

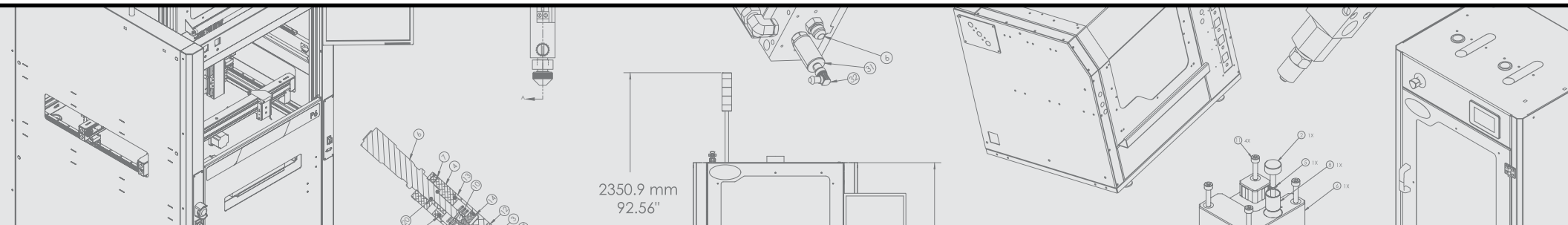



### Delta 8 Selective Coating/Dispensing System

The Delta 8 is a flexible robotic conformal coating/dispensing system that is ideal for selective coating, potting, bead, and meter-mix dispensing applications. Conceptualized for maximum flexibility, the Delta 8 can be utilized in both inline or batch operations.

#### Footprint

1046 mm x 1270 mm x 2350.9 mm  
(41.18 in x 50.0 in x 92.56 in)

#### Work Area (1 Valve/Tool)

621 mm x 595 mm x 100 mm  
(24.45 in x 23.43 in x 3.94 in)

#### XYZ Repeatability

±25 microns (±0.001 in)

Configuration shown includes PathMaster X.

#### Sample Configuration 1: Servo Adjusted Dual Tooled Coating<sup>+</sup> Δ

##### Dispense Head

4 station dispense head dual tooled, servo adjustable, 32 - 200 mm

##### Fluid Delivery

10 gallon tank  
2 gallon flip top tank

##### Valves

FC100-MC  
FCS300-ES

##### Additional Options

Fiducial camera  
Black light

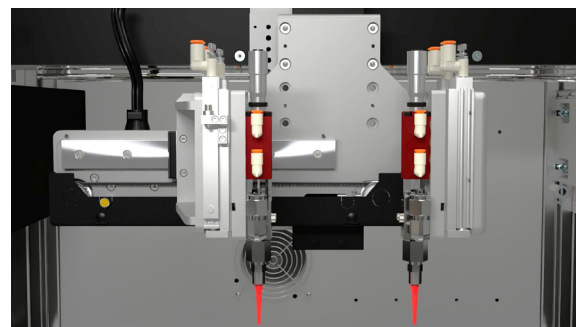

#### Sample Configuration 2: Dual Tooled Coating<sup>+</sup> Δ

##### Dispense Head

4 station dispense head dual tooled, manually adjustable, 32 - 200 mm

##### Fluid Delivery

10 gallon tank  
2 gallon flip top tank

##### Valves

FC100-MC  
FCS300-ES

##### Additional Options

Fiducial camera  
Black light

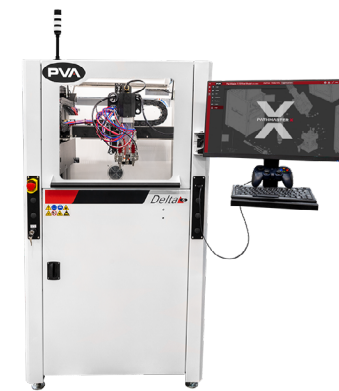
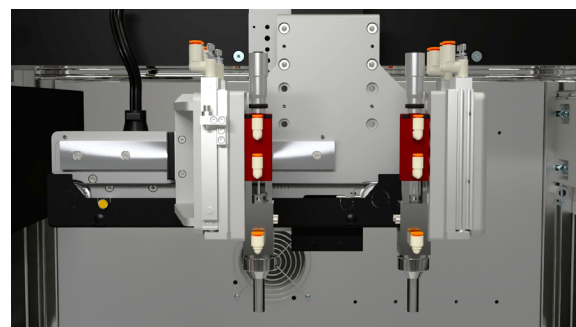

### Delta 6 Selective Coating/Dispensing System

Designed with a slimmer footprint, the Delta 6 is a re-imagined flexible robotic conformal coating/dispensing system that is ideal for selective coating, potting, bead, and meter-mix dispensing applications. Featuring a robust overhead three-axis motion platform, the Delta 6 is suitable for inline or batch operations.

#### Footprint

847 mm x 1136.9 mm x 1606 mm  
(33.35 in x 44.76 in x 63.23 in)

#### Work Area (1 Valve/Tool)

521 mm x 485 mm x 100 mm  
(20.51 in x 19.09 in x 3.94 in)

#### XYZ Repeatability

±25 microns (±0.001 in)

Configuration shown includes PathMaster X.

#### Sample Configuration 1: 3-Axis Coating<sup>+</sup> Δ

##### Dispense Head

2 station dispense head with two position tilt on station 2

##### Fluid Delivery

10 gallon tank  
2 gallon flip top tank

##### Valves

FC100-MC  
FCS300-ES

##### Additional Options

Fiducial camera  
Needle calibration  
Black light

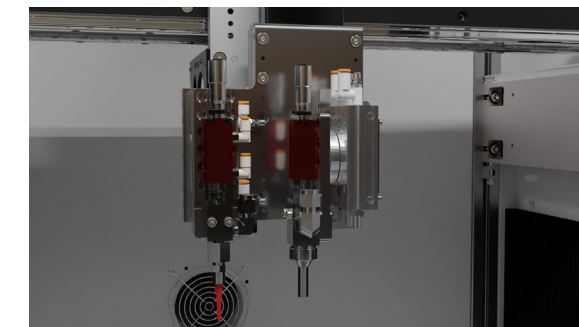

#### Sample Configuration 2: CF 3-Axis Coating with Continuous Film Calibration<sup>+</sup> Δ

##### Dispense Head

3 station dispense head with twist on station 2 and tilt on station 3

##### Fluid Delivery

10 gallon tank  
2 gallon flip top tank

##### Valves

FC100-MC  
FCS300-ES  
FC100-CF

##### Additional Options

Fiducial camera  
Laser fan width sensor for CFC

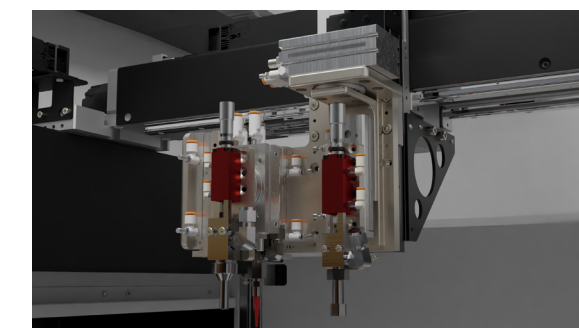

### Sample Configuration 3: Dispense and Coat<sup>+</sup> <sup>Δ</sup>

#### Dispense Head

High pressure 3 station dispense head with two position tilt on stations 2 & 3

#### Valves

FC100-MC with high pressure hose  
FC100-MC  
FCS300-ES

#### Fluid Delivery

10 gallon tank  
2 gallon flip top tank

#### Additional Options

Fiducial camera  
Needle calibration  
Black light

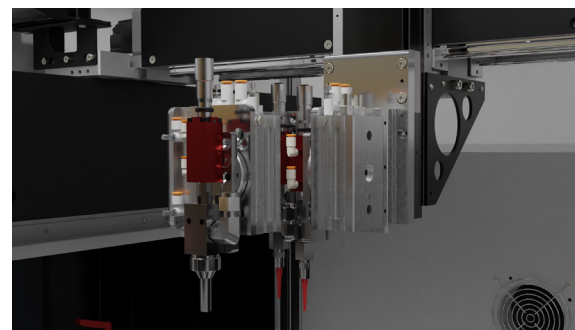

### Sample Configuration 5: CF 4th Axis Coating with CFC<sup>+</sup> <sup>Δ</sup>

#### Dispense Head

Servo 4th axis with three dispense stations and two position tilts

#### Valves

FC100-MC  
FCS300-ES  
FC100-CF

#### Fluid Delivery

10 gallon tank  
2 gallon flip top tank

#### Additional Options

Fiducial camera  
Laser fan width sensor for CFC  
Needle calibration  
Black light

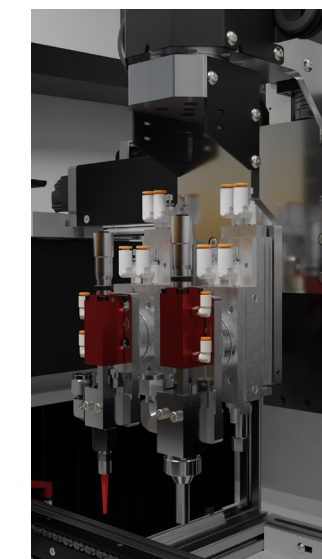

### Sample Configuration 4: 4-Axis Coating<sup>+</sup> <sup>Δ</sup>

#### Dispense Head

Servo 4th axis with three dispense stations and two position tilts

#### Valves

FC100-MC  
FCS300-ES  
FCM100

#### Fluid Delivery

10 gallon tank  
2 gallon flip top tank

#### Additional Options

Fiducial camera  
Needle calibration  
Black light

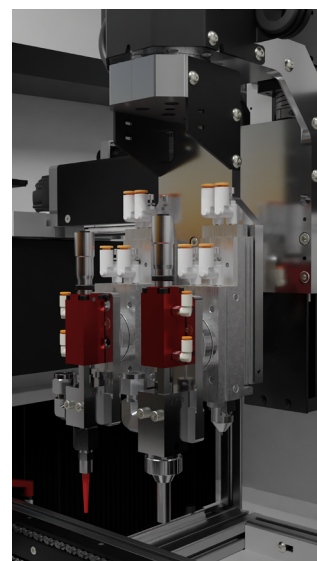

### Sample Configuration 6: 5 Gallon Dispense<sup>+</sup> <sup>Δ</sup>

#### Dispense Head

Two station dispense head

#### Valves

FC100-MC with high pressure hose

#### Fluid Delivery

5 gallon pail pump with low level sensor

#### Additional Options

Fiducial camera  
Needle calibration

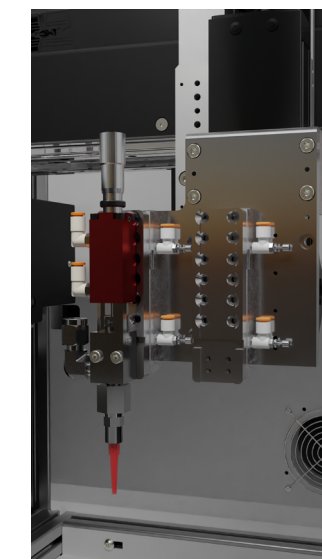

<sup>+</sup> Part handling: Edge chain conveyor - manual adjust (left to right)

<sup>Δ</sup> Utilities: Exhaust - 300 CFM • Compressed air - 80 - 100 psi • Current - 12A



## Endurance Dispensing Metering Module

The Endurance dispensing package bundles multiple dispensing and pumping technologies into one complete and versatile solution. The dispensing control system on Endurance can be configured to operate as a standalone manual application or fixed valve application with a manual push button or foot pedal activation. It can also be integrated with a PVA automation workcell or with a customer provided automation system.

### Footprint

685 mm x 600 mm x 805 mm  
(26.96 in x 23.62 in x 31.69 in)

### Sample Configuration 1: Integrated Gear Pump<sup>xθ</sup>

#### Dispense Modules (Left & Right)

SGP030 Servo Gear Pump, 3.0 cc

#### Fluid Delivery

(2) 10 gallon tanks

#### Module Shot Size (ml)

Minimum - 0.75  
Maximum - 9999

#### Module Flow Rates (ml/min)

Minimum - 15  
Maximum - 240

#### Mixed Flow at 1:2 Ratio (ml/min)

Left (Minimum) - 45  
Right (Maximum) - 360

#### Mixed Shot Size at 1:2 Ratio (ml)

Left (Minimum) - 2.25  
Right (Maximum) - 14999

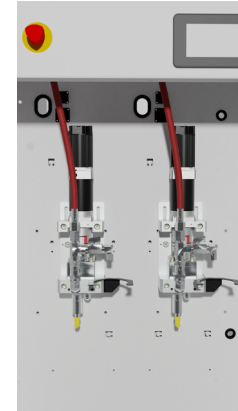

### Sample Configuration 2: Integrated Piston Pump<sup>xθ</sup>

#### Dispense Modules (Left & Right)

SPP080 Servo Gear Pump

#### Fluid Delivery

(2) 10 gallon tanks

#### Module Shot Size (ml)

Minimum - 0.1  
Maximum - 80

#### Module Flow Rates (ml/min)

Minimum - 0.1  
Maximum - 600

#### Mixed Flow at 1:2 Ratio (ml/min)

Left (Minimum) - 0.3  
Right (Maximum) - 900

#### Mixed Shot Size at 1:2 Ratio (ml)

Left (Minimum) - 0.3  
Right (Maximum) - 120

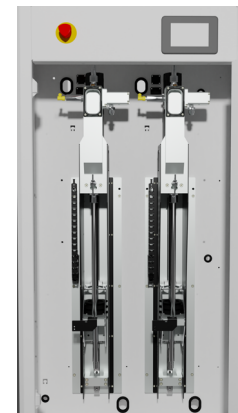

### Sample Configuration 3: Cartridge Dispense<sup>xθ</sup>

#### Dispense Modules (Left & Right)

SCTP020 Servo Cartridge Pump, 20oz

#### Fluid Delivery

20 oz / 600 cc SEMCO Cartridge

#### Module Shot Size (ml)

Minimum - 0.5  
Maximum - 591

#### Module Flow Rates (ml/min)

Minimum - 0.1  
Maximum - 300

#### Mixed Flow at 1:2 Ratio (ml/min)

Left (Minimum) - 0.3  
Right (Maximum) - 450

#### Mixed Shot Size at 1:2 Ratio (ml)

Left (Minimum) - 1.5  
Right (Maximum) - 887

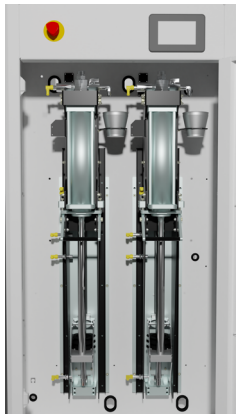

### Sample Configuration 4: Stand Alone Gear Pump<sup>xθ</sup>

#### Dispense Modules (Left & Right)

SGP030 Servo Gear Pump, 3.0 cc

#### Fluid Delivery

(2) 10 Gallon Tank

#### Valve

DX100-CR

#### Module Shot Size (ml)

Minimum - 0.75  
Maximum - 9999

#### Mixed Shot Size at 1:2 Ratio (ml)

Left (Minimum) - 1.5  
Right (Maximum) - 887

#### Module Flow Rates (ml/min)

Minimum - 0.1  
Maximum - 300

#### Mixed Flow at 1:2 Ratio (ml/min)

Left (Minimum) - 0.3  
Right (Maximum) - 450

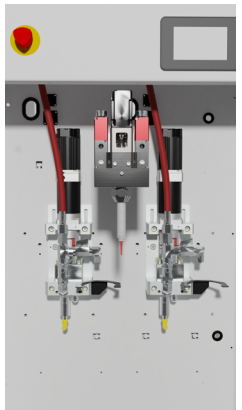

<sup>x</sup> Utilities: Exhaust - 250 CFM • Compressed air - 80 psi dry unlubricated • Voltage - 100v, 120v/50-60Hz

<sup>θ</sup> No vacuum degas required



## Sigma Benchtop Coating/Dispensing System

The Sigma benchtop is a compact three-axis robotic gantry ideal for automating a variety of dispensing and coating applications. Featuring multiple mounting positions, users can easily incorporate multiple chemistries or application techniques into their process.

### Footprint

743 mm x 643 mm x 805 mm  
(29.25 in x 25.32 in x 31.69 in)

### Work Area (1 Valve/Tool)

330 mm x 300 mm x 100 mm  
(13.00 in x 11.81 in x 3.94 in)

### XYZ Repeatability

±50 µm (±0.002 in)

### Sample Configuration 1: Coating<sup>≠</sup>

#### Dispense Head

2 station dispense head

#### Fluid Delivery

(2) 6 oz cartridge retainer with low level sensor

#### Valves

FC100-MC  
FCS300-ES

#### Additional Options

Black light

#### Part Handling

Adjustable PCB fixture

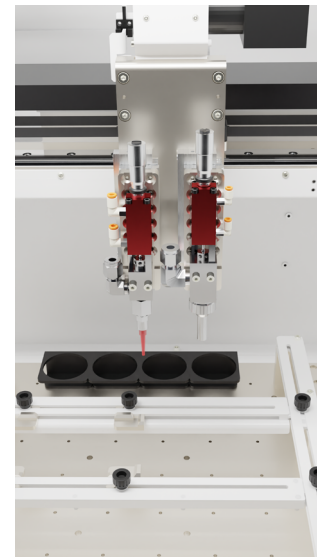

### Sample Configuration 2: 1 Station Dispense Head<sup>≠</sup>

#### Dispense Head

1 station dispense head

#### Fluid Delivery

310 ml cartridge pump with low level sensor

#### Part Handling

Tooling plate

#### Valves

FC100-MC with high pressure hose

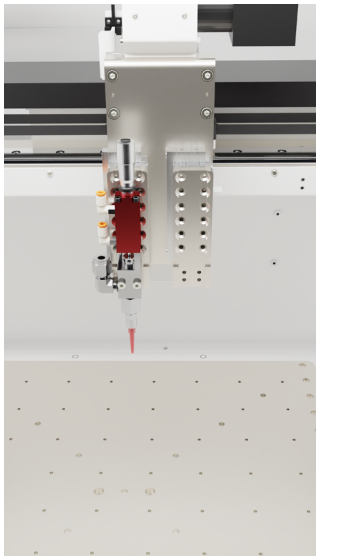

### Sample Configuration 3: 2K BiPack<sup>≠</sup>

#### Dispense Head

Square BiPack

#### Part Handling

Tooling plate



<sup>≠</sup> Utilities: Exhaust - 250 CFM • Compressed air - 80 - 100 psi • Current - 10A



**DeltaTherm**  
Infrared Curing Oven

The DeltaTherm utilizes infrared panels to efficiently cure adhesives and coatings in a controlled, heated environment. Featuring a double-sided configuration, the DeltaTherm offers custom top and bottom heat profiling in each two foot section. Optional humidity control feature allows for further control of moisture cure applications.

**Footprint (8ft)\***

2573 mm x 1043 mm x 53.78 mm - 56.73 mm  
(101.29 in x 41.06 in x 53.78 in - 56.73 in)

**Curing Length**

1.2 m / 2.4 m / 3.7 m / 4.8 m  
(4 ft / 8 ft / 12 ft / 16 ft)

**Max. Panel Temp.**

260 °C  
(500 °F)

\*Length dimension will vary based on oven selection

**Sample Configuration 1: 8 Foot Double Sided Infrared Oven<sup>S¥</sup>**

**Component Clearance**

Maximum 100 mm (4 in), top and bottom

**Conveyor Height (From Floor)**

890 mm to 965 mm (35 in to 38 in),  
SMEMA standard

**Board/Pallet Width**

50 mm to 500 mm  
(1.9 in to 19.6 in)

**Conveyor Speed**

0.03 m/min to 15.24 m/min  
(0.1 ft/min to 50 ft/min)

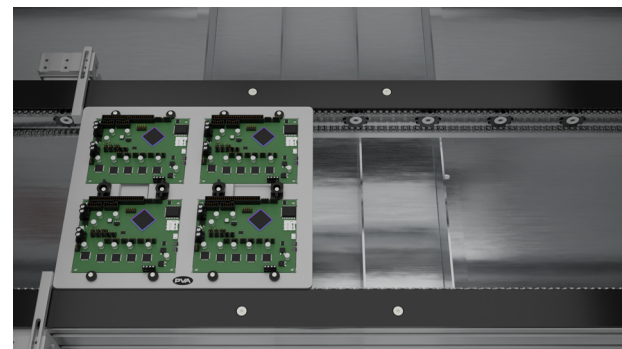

<sup>S</sup>Part handling: Pin chain conveyor with hand crank, left to right

<sup>¥</sup>Utilities: Exhaust - 300 CFM • Current - 40 A • Voltage - 440 - 480v, 3Ø, Delta, 50/60Hz

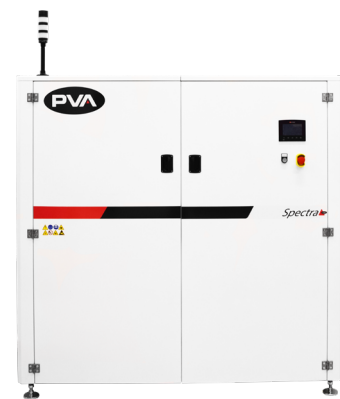

**Spectra**  
UV Curing Oven

The Spectra features Fusion® UV lamps by Heraeus to initiate fast ultraviolet light polymerization of adhesives and coatings in an efficient inline process. Various beam widths are available to accommodate a wide range of substrate dimensions.

**Footprint**

1651 mm x 1066.8 mm x 1661.16 mm  
(65 in x 42 in x 65.4 in)

**Working Width**

50 mm to 500 mm  
(1.97 in to 19.69 in)

**UV Beam Widths**

167.64 mm, 335.28 mm, 502.92 mm  
(6.6 in, 13.2 in, 19.8 in)

**Sample Configuration 1: UV Curing - Top Only<sup>¶Σ</sup>**

**Component Clearance**

Maximum 101.6 mm (4 in), top and bottom

**Conveyor Height (From Floor)**

890 mm to 965 mm (35 in to 38 in),  
SMEMA standard

**Lamp Quantity (Per Side)**

(2) 6 in Lamps - 13.2 in curing width

**Lamp Height (Above Conveyor)**

51 mm to 152.4 mm  
(2 in to 6 in)

**Bulb Type**

H+

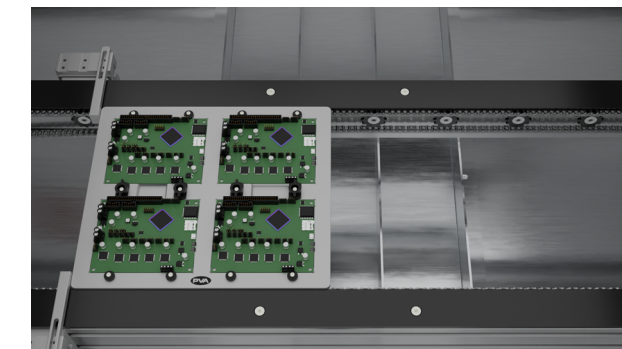

<sup>¶</sup>Part handling: Edge chain conveyor with hand crank, left to right

<sup>Σ</sup>Utilities: Exhaust - 600 CFM, includes low level flow alarm • Current - 45 A • Compressed air - 80 - 100 psi • Voltage - 208v, 3Ø, Delta, 60Hz







**BI2000**  
**Board Inverter**

The BI2000 is a compact inverting module for use with printed circuit boards and pallets within an inline process. While configured in a PVA production line, the BI2000 exposes the underside of an assembly for processing. Once inverted, the assembly can continue on to the next module, or return to the original workstation in a bi-directional mode.

**Footprint**

1059 mm x 636 mm x 1827.7 mm  
(41.7 in x 25 in x 72 in)

**Working Width**

50 mm - 500 mm  
(1.96 in - 19.68 in)

**Component Clearance**

100 mm (4 in), top and bottom  
4.75 mm (0.1875 in) for edge carrying (SMEMA)

**Sample Configuration 1:** Board Inverter, Edge Chain <sup>†‡</sup>

**Conveyor Height (From Floor)**

890 mm to 965 mm (35 in to 38 in),  
SMEMA standard

**Conveyor Speed**

0.15 m/min to 24 m/min  
(0.5 ft/min to 80 ft/min)

**Maximum Pallet Length**

550 mm  
(21.65 in)

**Maximum Pallet Weight**

4.5 kg  
(10 lbs)

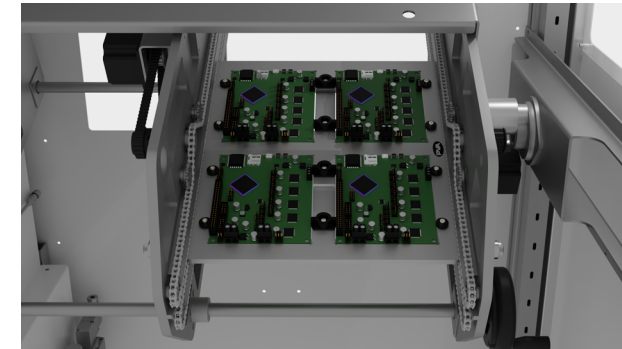

**Queue**  
**Inspection Conveyor**

The Q Series Inspection Conveyors are ideal for a wide range of path handling applications and can optimize material flow between processes. PVA conveyor systems can be used to transport bare board assemblies or pallet fixtures. A standard black light is included for inspection purposes.

**Footprint**

1046 mm x 1003 mm x 2022.9 mm  
(41.18 in x 39.5 in x 79.65 in)

**Working Width**

50 mm to 500 mm  
(1.97 in to 19.69 in)

**Component Clearance**

100 mm (4 in), top and bottom  
4.75 mm (0.1875 in) for edge carrying (SMEMA)

**Sample Configuration 1:** Conveyor with Black Light Inspection <sup>∞‡</sup>

**Conveyor Height (From Floor)**

890 mm to 965 mm (35 in to 38 in),  
SMEMA standard

**Conveyor Speed**

0.15 m/min to 24 m/min  
(0.5 ft/min to 80 ft/min)

**Maximum Pallet Weight**

4.5 kg  
(10 lbs)



<sup>†</sup>Part handling: Edge chain conveyor

<sup>‡</sup>Utilities: Exhaust - 0 CFM • Current - 5 A • Compressed air - 80 - 100 psi • Voltage - 100 - 240v, 50/60Hz

<sup>∞</sup> Part handling: Edge chain conveyor with hand crank rail width adjustment, left to right

<sup>‡</sup> Utilities: Exhaust - 300 CFM • Current - 5 A • Compressed air - N/A • Voltage - 100 - 120v, 50 - 60Hz



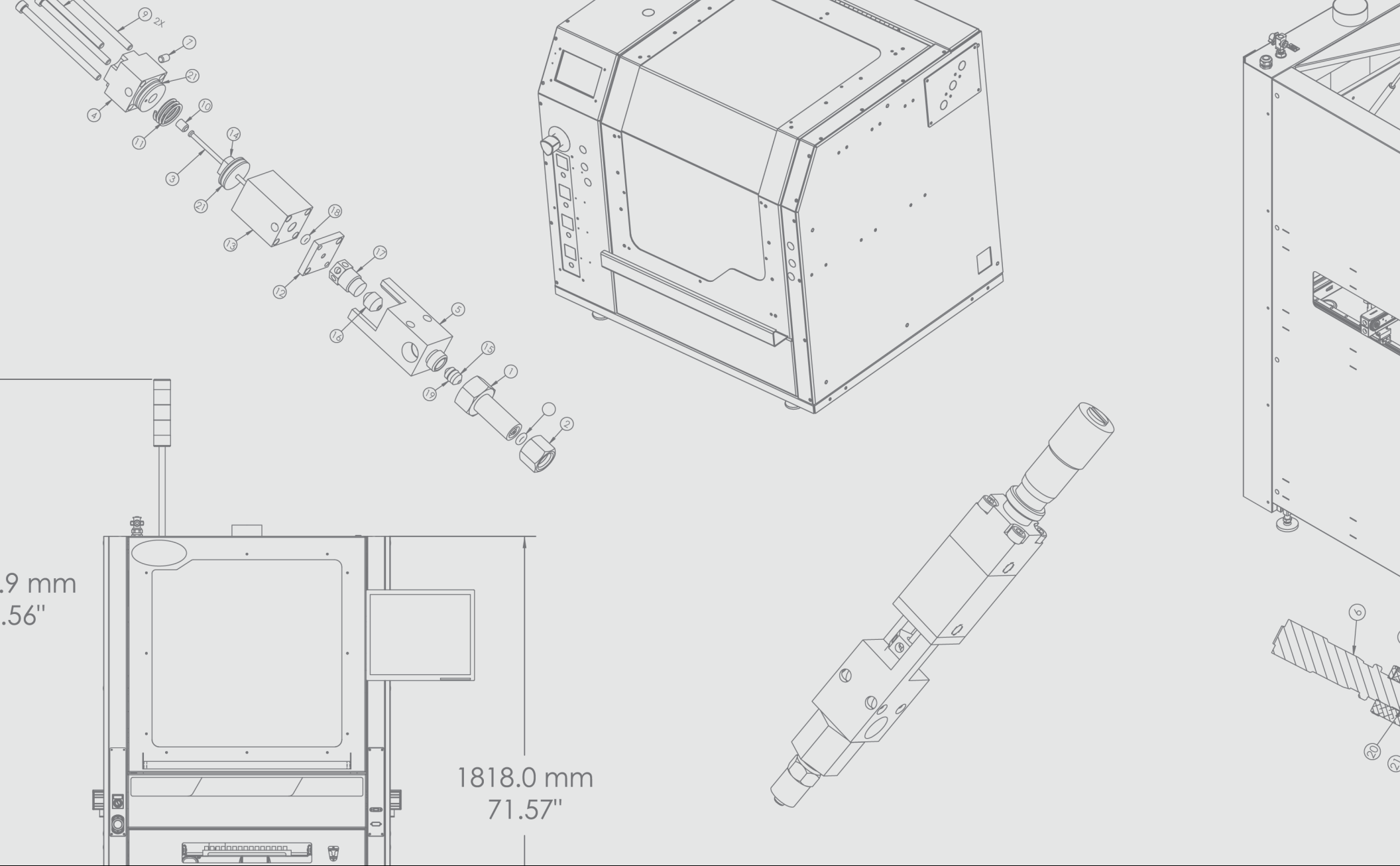

**Global Headquarters**

6 Corporate Drive  
 Halfmoon, NY 12065  
 info@pva.net  
 +1-518-371-2684

**Asia Pacific Headquarters**

#104, The Sharp Center City Apt,  
 East-Daegu Station  
 Daegu, Korea  
 pkim@pva.net  
 +82-10-5646-8085

**Asia Headquarters**

Room 301, Blk#B, Ascendas Xinsu Square  
 No. 5 Xinghan St, SIP  
 Suzhou, P.R. China 215021  
 fpeng@pva.net  
 +86-512-8766-0918

**Europe Headquarters**

Engelseweg 235 NL - 5705AE  
 Helmond, Netherlands  
 pvdv@pva.net  
 +31-492-792729

**Mexico Headquarters**

Parque Pinar Empresarial  
 Camino al Cucba #175. Nave -#81  
 Col. Venta del Astillero  
 Zapopan, Jalisco 45221  
 dgomez@pva.net