

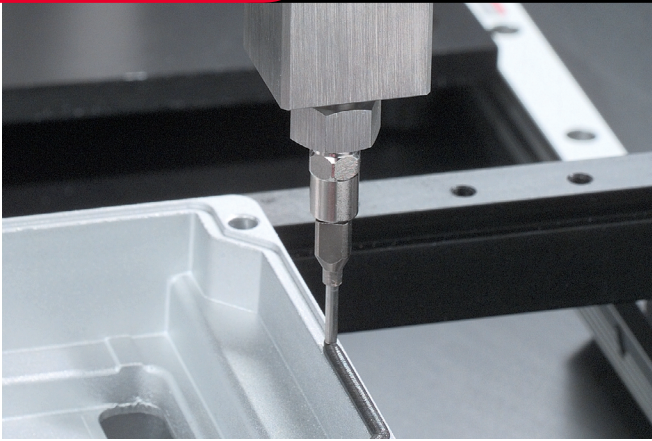

INNOVATION. **PRECISION.** EXCELLENCE.



System Specifications

CP Series Systems

PVA300MLCP - For 300 ml cartridges

PVA060ZCP - For 6 oz cartridges

PVA120ZCP - For 12 oz cartridges

PVA200ZCP - For 20 oz cartridges

Footprint

550 mm x 233 mm (21.6 in x 9.17 in)

Pump Mechanism

Air operated mini extruder

Pump Ratio

9:1

Maximum Fluid Outlet Pressure

1200 psi at 100 psi air

Maximum Air Inlet Range

80 - 100 psi

Weight

40 lbs (18.1 kg)

Cartridge Pump CP Series

CP Series Pumps are ideal for dispensing medium to high viscosity materials pre-packaged in cartridges that require high flow rates than available with air pressure alone. Possible applications include gasketing, sealing, lubricating and filling. The CP Series Pumps can be used with a hand held or automated dispensing systems.

The CP Series Pump has many options and integrated features including:

- 9:1 ratio system to create high fluid pressure
- Locking cartridge retainer
- Pneumatic control panel
- Accommodates multiple cartridge sizes and types
- Includes material hose, fluid regulator and gauges
- Compact footprint
- Optional low level sensor

For more information, please contact PVA at info@pva.net or contact your local representative.

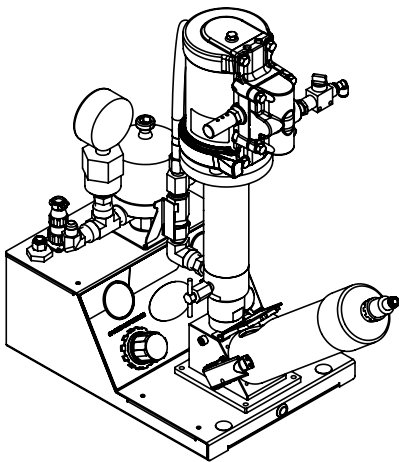

300 ml CARTRIDGE

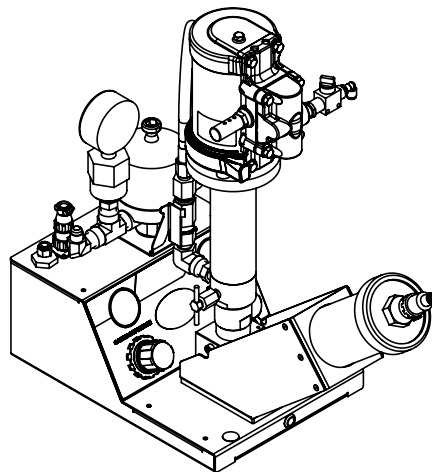

6/12/20oz CARTRIDGE

Headquarters
6 Corporate Drive | Halfmoon, NY 12065
tel +1 518 371 2684 | fx +1 518 371 2688
www.pva.net | info@pva.net