

MV300

POSITIVE DISPLACEMENT VALVE

Version: B12-2381

Operation Manual



**SIX CORPORATE DRIVE
HALFMOON, NY 12065
PHONE: 518-371-2684
FAX: 518-371-2688**

**info@pva.net
www.pva.net**



MV300

Metering Valve, Positive Displacement Dispense Valve

Thank you for purchasing the MV300 dispensing valve from PVA. Before attempting to operate the MV300, we recommend that you take a few minutes and read the following operation and setup manual. This will assist in familiarizing you with the product and ensure a successful installation.

As always, if any questions or problems arise, do not hesitate to contact PVA's Valve Service Department for support. This department can be reached at PVA headquarters via telephone or e-mail.

Again, thank you for your purchase, and we look forward to assisting you in the future as you continue to improve your dispensing processes.

Theory of Operation

The MV300 is a rod displacement style metering valve designed to dispense small volumes of fluid with the highest degree of accuracy. This true positive displacement valve will dispense one small dot of fluid with each full cycle. Fluid volume is determined by the stroke adjustment setting and cannot be affected by changes in fluid viscosity due to temperature or changes in fluid delivery pressure.

MV300 volumetric fluid displacement range:

(0.010 cc – 0.125 cc)

The MV300 has a divorced design comprising of two major sections. These include:

- 1) Air section (red anodized portion)
- 2) Fluid section (stainless steel portion)

The air section is an aluminum body with a simple piston/cylinder combination used to cycle the valve. A stroke adjustment bolt in the upper air body controls how far the piston and needle assembly can retract thus altering the volume of fluid that can be metered and dispensed during each cycle.

The fluid section is a stainless steel body, which includes a needle, seat, and two integral check valves to make up the metering chamber. The metering chamber fills as the needle retracts away from the seat, then dispenses as the needle moves back toward the seat. Such fluids may include but are not limited to; epoxies, UV adhesives, silicones, RTV, grease, etc.

Wetted parts on the MV300 include:

- 303, 304 stainless steel
- Teflon
- Delrin
- Kalrez

Safety

Due to material contents being under pressure eye protection is required for operators. Refer to MSDS sheets on material being dispensed for other precautions.

Setup

The MV300 requires a 2-position, 4-way air solenoid valve to actuate the air section. The valve should be operated with clean, dry air between 60-100psi. Two #10-32 threaded air ports are located on the air section of the valve. The port located closest to the mid-section of the valve is air actuating to fill the fluid chamber. The port located furthest from the mid-section of the valve is air actuating to dispense material. Quick connect air fittings are typically supplied with the MV300 to fit 5/32" od tubing. Note that the valve should be normally in the filled and ready to dispense position.

Fluid is supplied to the MV300 through the 1/4" npt port located on the stainless steel fluid section of the valve.

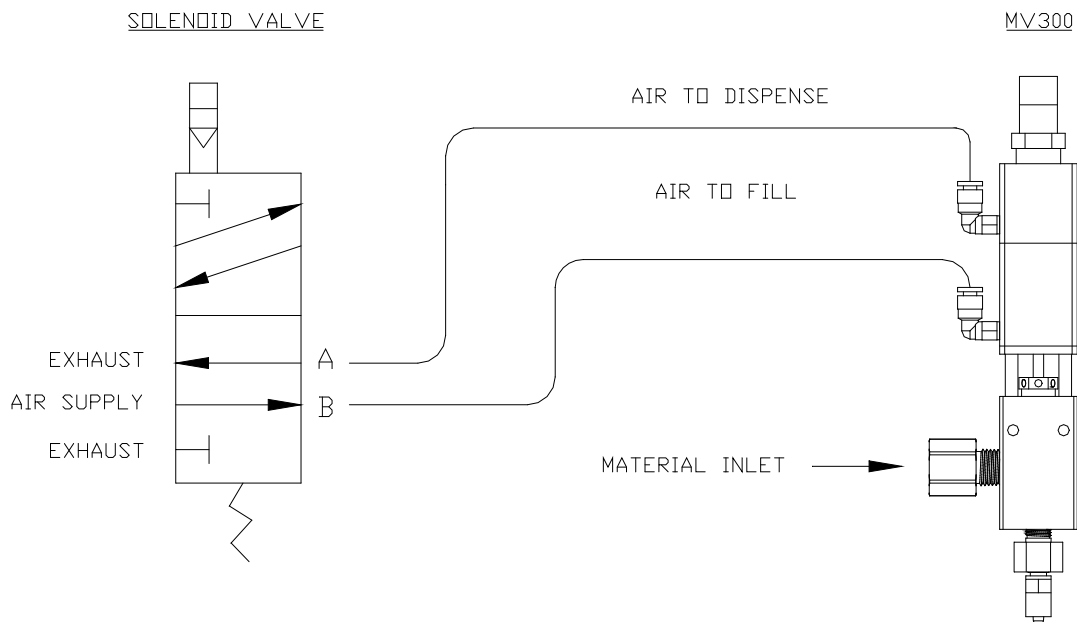

Tool Kit

PVA offers standard tool kits for all dispensing valves. The tool kit for the MV300 is part number **B12-1938**, which includes all necessary tools and lubricating grease to perform maintenance on this dispense valve:

B12-1938 Includes:

Qty	Part Number	Description
2	0266244	8" Adjustable Wrench
2	26563	3/32" Allen Key
1	26571	5/32" Allen Key
1	5516A18	Tweezers
1	B62-0752	Mineral Oil Lubrication Kit, 2.5cc
1	B62-2048	Silicone Lubricant for o-ring, 2.5cc
1	9570K71	Hook and Pick Set
1	0266255	Pliers
2	53085A61	Soft Plastic Covers for Pliers
1	TT-14	Teflon Tape
1	MM115	Removable Thread Locker

Operation

Refer to assembly drawings **112-3523** for part reference numbers.

- 1) Plumb up the valve as outlined above in the **Setup** procedure.
- 2) Regulate the air pressure operating the valve between 60-100psi.
- 3) Making sure that the valve is not aimed toward anyone, cycle the valve several times. When the valve is cycling, the piston can be heard hitting the stroke adjustment bolt, and the needle (3) can be seen going up and down in the center. If the valve is not cycling properly, refer to the **Troubleshooting** section.
- 4) When the fluid delivery system is connected to the valve, pressurize the material to be dispensed between 5-10 psi.
- 5) To bleed the fluid section, use a 3/32" Allen key loosen the set screw (27) of the bleed port located on the fluid section (4), being careful not to fully remove the screw. Note: If fluid does not flow out of the bleed port, slowly increase material pressure until fluid and air bubbles are seen. (Do not exceed 20psi. for purging)
- 6) Once material begins to flow steadily and all air bubbles have been bled, tighten the set screw (27) and wipe the valve body clean.
- 7) Open the stroke on the valve to full by turning the stroke adjustment bolt (13) counter clockwise until it reaches its stopping point.
- 8) If possible turn the valve vertical so the dispense tip is pointing up in the air. Note: Hold a cloth over the dispense tip to catch fluid flow from the tip.
- 9) Cycle the valve several times until material begins to dispense. Continue to cycle the valve until all air bubbles cease to dispense from the tip and a steady flow of material can be seen with each shot.

* Note: If material is dispensing properly, Skip the **Additional Bleeding** section

Additional Bleeding

Entrapped air inside the fluid section of this metering valve will greatly reduce the repeatability of the dispense volumes or even cause the valve to cease dispensing. Air bubbles trapped in this chamber will compress thus altering the amount of fluid that can pass the outlet check valve and dispense. For additional bleeding:

- 1) Mount the valve in a vertical position where the dispense tip is pointed straight up or straight down (no angle).
- 2) Apply pressure to the air section of the valve as stated in the Setup procedure such that the piston (11) assembly will be retracted and the needle (3) will be drawn back from the seat (2).
- 3) Pressurize the material to be dispensed between 5-10 psi.
- 4) Using an adjustable wrench, loosen the hex nut (1) then slowly unthread by hand until material begins to flow from the dispense tip and all air is bleed from the valve. Retighten the hex nut to the fluid section (4) using an adjustable wrench.
- 5) Once again cycle the valve several times until the fluid can be seen dispensing from the tip with some force behind it.

Setting Dispense Volume

- 1) Once all air is eliminated from the metering chamber, the stroke adjust bolt (13) can be used to set a specific shot volume to be dispensed each cycle.
- 2) Turning the stroke adjustment bolt (13) clockwise will decrease the material in each shot, and turning it counter-clockwise will increase the amount of material in each shot. If the stroke adjust bolt is turned all the way down it will not allow fluid to be dispensed.
- 3) Once the stroke adjustment setting is determined, tighten the lock nut (12) up against the upper air body (10) to hold the stroke adjustment (13) in place.

Note: Refer to **Troubleshooting** section for any problems.

Periodic Maintenance

Refer to the MV300 cross sectional view for location of parts referenced in the following procedures.

- 1) Lubricate the packing (5) on the MV300 valve every 200 hrs by placing a few drops of mineral oil or other light oil inside the packing nut (6).
*Note: PVA offers a 2.5cc mineral oil lubrication kit; Part#: B62-0752
- 2) The packing nut (6) may require occasional tightening, as wear occurs in order to prevent leaks through the packing.

Routine Cleaning and Disassembly

Cleaning and rebuilding the valve will be required from time to time. A spare parts kit, part # **MV3-SP** is available with all the normal wear parts included.

- 1) Begin disassembly by removing air and fluid pressure from the valve.
- 2) Remove all pneumatic tubing and fluid delivery fittings, hoses, etc. from the valve.
- 3) Using the tip of a 3/32" Allen key, loosen the packing nut (6).
- 4) Using the same 3/32" Allen key, evenly remove two of the machine screws (21) that thread into the standoffs (7). Note: During removal that there is a spring (20) forcing the air section away from the fluid section.
- 5) Pull the air section (red anodized portion) away from the fluid section (stainless steel portion).
- 6) Clean off the tip of the stainless steel needle (3).
- 7) From the fluid section of the valve, unthread and remove the packing nut (6), followed by the packing (5).
- 8) Using an adjustable wrench, unthread and remove the luer adapter (14) from the needle adapter (1) followed by the washer (15).
- 9) Using the same adjustable wrench, unthread and remove the needle adapter (1) from the fluid section (4).
- 10) Remove the outlet check valve assembly (23, 24, 25) from the needle adapter (1).
- 11) Using an adjustable wrench, unthread and remove the inlet check valve (26) from the fluid section (4).
- 12) Remove the seat (2) from the fluid section (4) and remove the 007 Kalrez o-ring (16) from the seat. Note: If stuck, the seat can be pushed through from the opposite side of the fluid section.
- 13) Clean all of the wetted parts thoroughly with an appropriate solvent.
- 14) On the air section, use a standard 3/32" Allen Key to evenly remove the final two machine screws (21) that thread into the end cap (8). Note: During removal that the spring (V080) will force the air section apart.
- 15) Separate the upper air body (10) from the lower air body (9) to remove the spring (20) then slide the end cap (8) off of the needle (3).
- 16) Holding the lower air body (9) in one hand, grab the needle (3) and push the needle and piston (11) assembly out of the lower air body.
- 17) Remove the 007 Buna o-ring (17) from the lower air body (9).
- 18) Hold the piston (11) with an adjustable wrench then use a 5/32" Allen key to unthread and remove the set screw (22) to remove the needle (3) then remove the 116 Buna o-ring (18) from the piston (11).
- 19) Remove the 116 Buna o-ring (18) from the upper air body (10) and the 011 Buna o-ring (19) from the stroke adjust bolt (13).
- 20) Unthread the stroke adjust bolt (13) from the upper air body (10) and remove the 011 Buna o-ring (19).

- Replace components with spares provided in the spare parts kit.

Assembly Instructions

General

- All o-rings must be lubricated with a small amount of silicone grease.
- A small amount of removable thread locker should be applied to the set screw (22) and the male thread of the standoffs (7).
- Assemble the air section and fluid section separately prior to connecting the two pieces.

Air Section

- 1) Assemble the stroke adjust (13) and lock nut (12) with the hex head toward the knurled end of the bolt.
- 2) Mount one 011 Buna o-ring (19) on the inside groove of the stroke adjust (13).
- 3) Thread the stroke adjustment assembly into the upper air body (10).
- 4) Mount one 116 Buna o-ring (18) on the end of the upper air body (10) and the other 011 Buna o-ring (19) on the end groove of the stroke adjust (13). Back out the stroke adjust by turning counter clockwise to the end of its travel.
- 5) Drop the needle (3) into the piston (11) and assemble with the set screw (22) using an adjustable wrench and 5/32" Allen key to tighten.
- 6) Mount the 116 Buna o-ring (18) onto the piston (11).
- 7) Apply a small amount of silicone grease to the inside of the lower air body (9) then drop in the piston (11) and needle (3) assembly.
- 8) Mount the 007 Buna o-ring (17) on the end of the needle (3) and slide it down into the groove in the end of the lower air body (9).
- 9) Slide the end cap (8) onto the needle up to the lower air body (9), place the spring (20) on top of the piston (11), and assemble the two air bodies using the two machine screws (21) that thread into the end cap. Tightening using a 3/32" Allen key. Note: Be sure the air holes are lined up on the same face and will align with the fluid inlet check valve (26).

Fluid Section

- 1) Screw the standoffs (7) into the fluid section (4) using soft tip pliers to tighten.
- 2) Drop the packing (5) into the fluid section (4), and screw in the packing nut (6) but leave finger tight until assembled with the air section.
- 3) Mount the 007 Kalrez o-ring (16) on the seat (2) and push the seat into the bottom of the fluid section (4). When inserting the seat, work the o-ring into the fluid body with finger to prevent shearing of the edge of the o-ring.

- 4) Holding the needle adapter (1) upright drop in the outlet spring (23), followed by the ball center (25), and ball (24).
- 5) Maintaining the upright position, thread the needle adapter (1) and check valve assembly (23, 24, 25) into the bottom of the fluid section (4). Tighten both pieces together using an adjustable wrench.
- 6) Place the small washer (15) into the end of the needle adapter (1) then thread the luer adapter (14) into the needle adapter and tighten with an adjustable wrench.
- 7) Place a small amount of Teflon tape on the male threads of the inlet check valve (26) then thread the inlet check valve into the 1/4" npt port on the fluid body (4) using an adjustable wrench to tighten.
- 8) Thread the set screw (27) into the fluid section (4) and tighten using a 3/32" Allen key.

Assemble Sections

- 1) Back out the stroke adjust bolt (13) by turning it counter clockwise until the end of its travel.
- 2) Apply a small amount of silicone grease to the end of the needle (3) then insert it into the packing nut (6) and slide the two sections together.
- 3) Align the air holes of the air section on the same face as the fluid inlet check valve (26) then connect the sections using the two machine screws (21) tightening them down evenly using a 3/32" Allen key.
- 4) Using the tip of a 3/32" Allen key, tighten the packing nut (6).

Spare Parts

PVA offers standard spare parts kits for all dispensing valves. These kits are stocked for immediate shipment and allow replacement of all wearable parts of the valve.

The spare parts kit for this valve, product number **MV3-SP**, includes the following components:

MV3-SP Includes:

Qty	Part Number	Description
1	V327	Seat
1	V328	Needle
1	V330	Packing
2	VLV-116B	116 Buna O-Ring
2	VLV-011B	011 Buna O-Ring
1	VLV-007K	007 Kalrez O-Ring
1	VLV-007B	007 Buna O-Ring
1	V125	Washer
1	V412	Ball Center
1	V055	Outlet Spring
1	V413-D	1/8" Delrin Ball

SECTION A-A

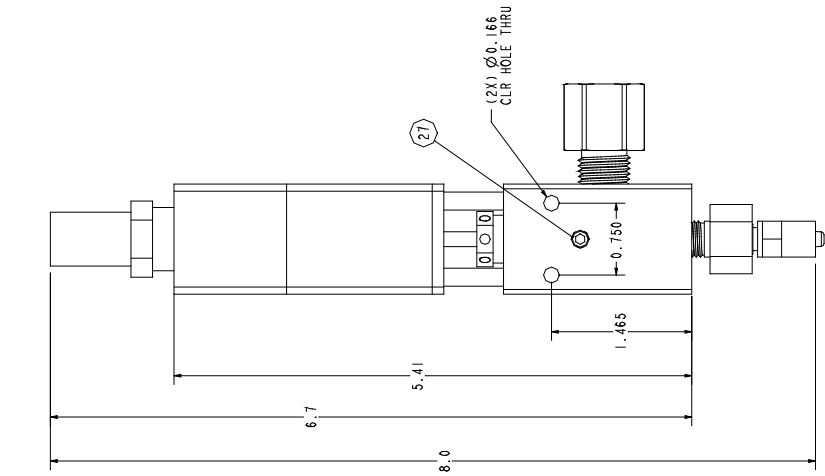
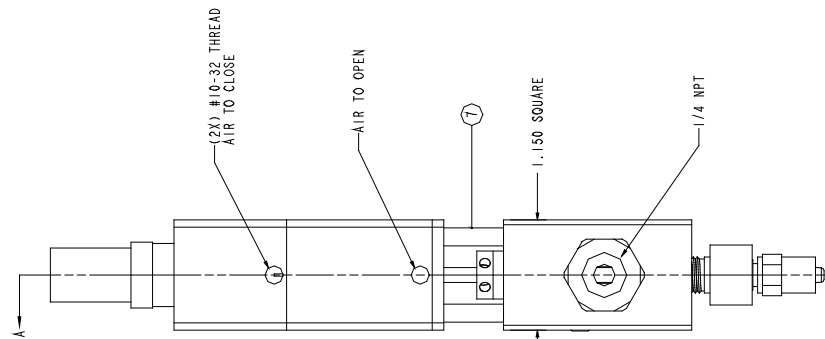
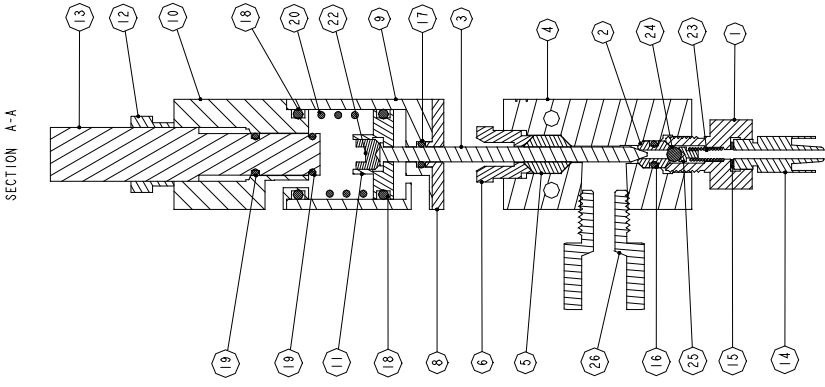

REV	REVISION DESCRIPTION	DRN BY	DATE	DESIGN REV	REVISION DESCRIPTION	DRN BY	DATE	DESIGN	MATERIAL:
A	REF. BOM # B12-2381	RJB	12JAN10	RJB					PVA
									TITLE: MV300
									DWG#: 112-3523
									QTY: -
									SHEET: 1 OF 1
									REV: A

FINISH: SURFACE FINISH: >

FINISH: SURFACE FINISH: >

THIS DOCUMENT, INCLUDING THE INFORMATION CONTAINED HEREIN, IS THE PROPERTY OF PRECISION VALVE & AUTOMATION, INC. AND IS CONSIDERED CONFIDENTIAL AND PROPRIETARY INFORMATION. IT IS DELIVERED ON THE EXPRESS CONDITION THAT IT NOT BE USED, DISCLOSED, OR REPRODUCED IN WHOLE OR IN PART, FOR ANY REASON WITHOUT PRIOR WRITTEN CONSENT OF PRECISION VALVE & AUTOMATION, INC.

BILL OF MATERIALS FOR MV300:

Version: B12-2381

Refer to Drawing: 112-3523

Item	Part Number	Description	Quantity
1	114-6344	Needle Adapter	1
2	V327	Seat	1
3	V328	Needle	1
4	114-6343	Fluid Section	1
5	V330	Packing	1
6	V331	Packing Nut	1
7	V075	Standoff	4
8	V222	End Cap	1
9	V223	Lower Air Body	1
10	V225	Upper Air Body	1
11	V224	Piston	1
12	V226	Lock Nut	1
13	V227	Stroke Adjust	1
14	V300	Luer Adapter	1
15	V125	Washer	1
16	VLV-007K	007 Kalrez O-Ring	1
17	VLV-007B	007 Buna O-Ring	1
18	VLV-116B	116 Buna O-Ring	2
19	VLV-011B	011 Buna O-Ring	2
20	V080	Spring	1
21	SH5-40x2.25	Socket Head Cap Screw	4
22	V079	Set Screw	1
23	V055	Spring	1
24	V413-D	1/8" Delrin Ball	1
25	V412	Ball Center	1
26	V418	Inlet Check Valve	1
27	V007	Plug	1

Troubleshooting

Problem	Possible Cause	Corrective Action
Valve does not cycle	<ul style="list-style-type: none"> - Air pressure to air section too low - Packing nut is too tight - Stroke adjustment bolt is bottomed out - Material is cured in the valve - Valve was assembled w/o lubricating the O-ring seals 	<ul style="list-style-type: none"> - Increase air pressure to 60-100 psi - Loosen packing nut until valve just begins to cycle, retighten - Back out stroke adjustment bolt by turning it counter-clockwise - Disassemble and clean valve - Disassemble valve, lubricate seals and re-assemble
Material leaks from valve tip	<ul style="list-style-type: none"> - Packing nut is too tight - Seat and/or ball are worn - Outlet spring is worn - Air bubble trapped in fluid body, needle adapter, or dispense needle 	<ul style="list-style-type: none"> - Loosen packing nut - Replace parts as necessary - Replace parts as necessary - Flip valve upside down and cycle until air bubbles are removed, or loosen set screw on fluid body to bleed air
Valve leaks from mid-section	<ul style="list-style-type: none"> - Packing nut is loose - Packing is worn 	<ul style="list-style-type: none"> - Tighten packing nut until snug - Replace packing
Valve does not dispense anything	<ul style="list-style-type: none"> - Air trapped in fluid body, needle adapter, or dispense needle - Valve is not cycling - Fluid pressure is too low - Material cured in fluid section - Stroke adjustment bolt set too low 	<ul style="list-style-type: none"> - Flip valve upside down and cycle until air bubbles are removed, or loosen set screw on fluid body to bleed air - See above - Increase fluid pressure - Disassemble and clean valve - Back out stroke adjustment bolt by turning it counter-clockwise
Air bubbles in fluid	<ul style="list-style-type: none"> - Valve not properly purged - Problem with fluid delivery system 	<ul style="list-style-type: none"> - Flip valve upside down and cycle until air bubbles are removed, or loosen set screw on fluid body to bleed air - Diagnose and repair.
Inconsistent shot sizes	<ul style="list-style-type: none"> - Improper material viscosity - Air trapped in material being dispensed 	<ul style="list-style-type: none"> - No solution - Flip valve upside down and cycle until air bubbles are removed, or loosen set screw on fluid body to bleed air

PVA Warranty Policy

PVA warrants the enclosed product against defects in material or workmanship on all components for one year from the date of shipment.

The warranty does not extend to components damaged due to misuse, negligence, or installation and operation that is not in accordance with the recommended factory instructions. Unauthorized repair or modification of the enclosed product, and/or the use of spare parts not directly obtained from PVA (or from factory authorized dealers) will void all warranties.

All PVA warranties extend only to the original purchaser. Third party warranty claims will not be honored at any time.

Prior to returning a product for a warranty claim, a return authorization must be obtained from PVA's customer service department. Authorization will be issued either via the telephone, facsimile, or in writing upon your request.

To qualify as a valid warranty claim, the defective product must be returned to the factory during the warranty period. Upon return, PVA will repair (or replace) all components found to be defective in material or workmanship.

(Retain this for your records)

Product Information:

PRODUCT: _____

SERIAL NUMBER: _____

DATE OF PURCHASE: _____